



My Voice!TM Alarm Clock

Important: Please save this instruction sheet. It contains valuable product information.

To Assemble the My Voice! Alarm Clock

1. Align the top with the base as shown (Fig. 1).
2. Press together firmly until it snaps together.
3. To change the clock face, pull outwards on the clear cover using the two tabs on the sides (Fig. 2).
4. Carefully remove the clock face and replace it with another of your choice.
5. Align the cutout around the LCD display.
6. Snap the clear cover back into place.

To Set the Time

1. Press MODE button once (Fig. 3). The clock digits will blink (Fig. 4).
2. Press HOUR button repeatedly until the correct hour is shown.
Note: The AM/PM symbol indicates morning or evening hours.
3. Press MIN button repeatedly until the correct minutes are shown.
4. Press MODE button three times to finish.

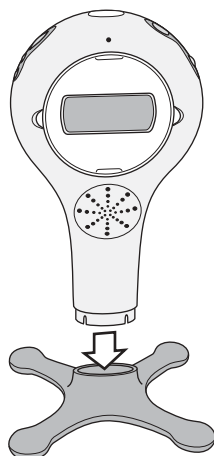
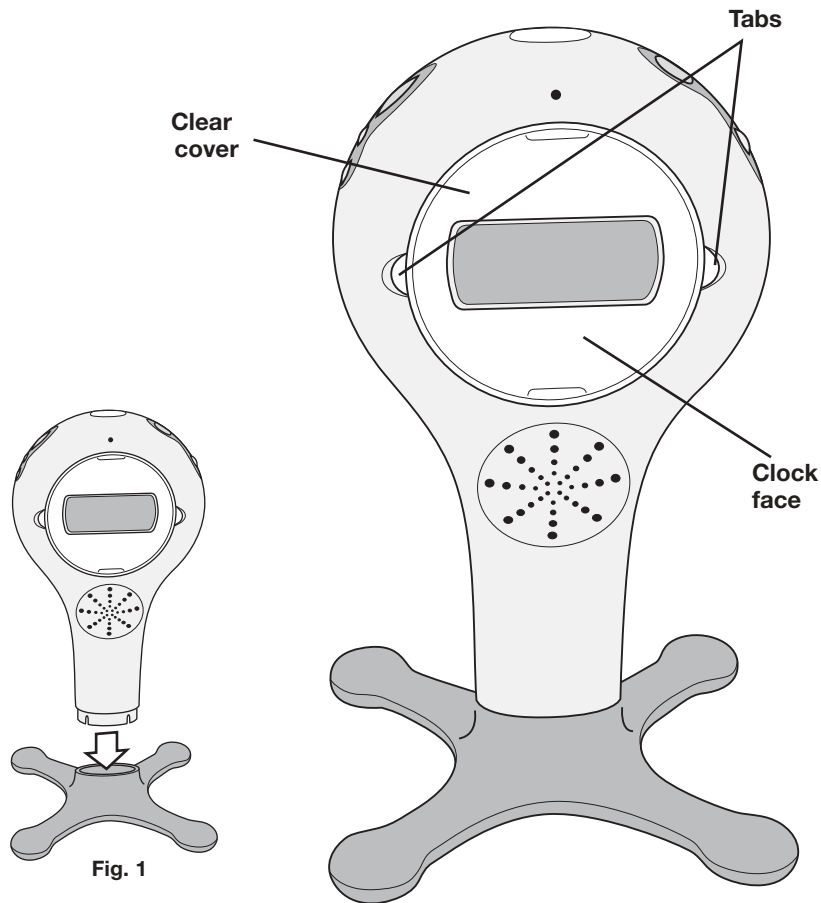

Fig. 1

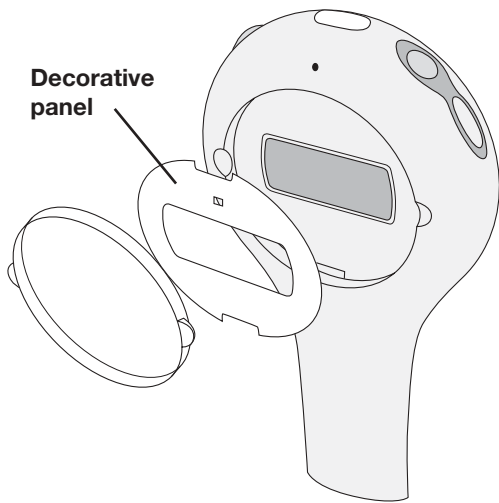

Fig. 2

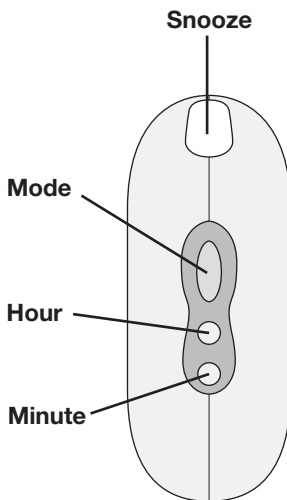

Fig. 3

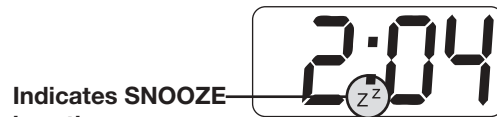
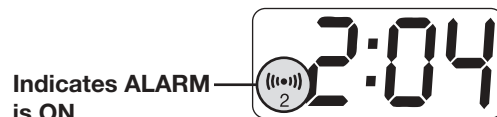
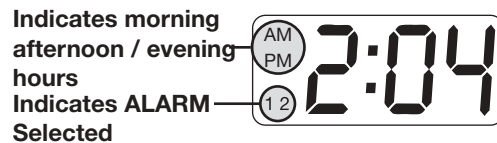

Fig. 4

To Set the Alarms

1. Press MODE button twice for ALARM 1 (Fig. 3). Press MODE button three times for ALARM 2.
2. The alarm digits will blink and "AL" will appear in the middle to indicate you are in alarm mode. A "1" or "2" will appear in the lower left to indicate which alarm mode you are setting.
3. Press HOUR button repeatedly to set the hour you would like the alarm to sound. Note: the AM/PM symbol indicates morning or evening hours.
4. Press MIN button repeatedly to set the minutes of the hour you would like the alarm to sound.
5. Press MODE button once more to set ALARM 2 and repeat steps 1, 2 and 3. Note: ALARM 2 can be set to the same time as ALARM 1. This lets you choose the preset recording or your own message for waking up at the same time.
6. Move the ALARM SET switch to ALARM 1 to wake up to the preset recording (Fig. 5).
7. Move the ALARM SET switch to ALARM 2 to wake up to your message (See Step 5 above).
8. To silence the alarm, move ALARM SET switch to the OFF position OR press SNOOZE button (Fig. 5) for 10 additional minutes of sleep.

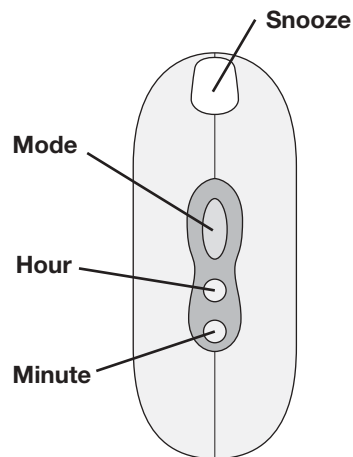

Fig. 3

To Record Your Personal Wake-Up Message

1. Think of a fun message that will wake you up! Your message can be up to 6 seconds long.
2. Press and hold RECORD/PLAY button for 3 seconds till you hear a beep (Fig. 5). While holding the RECORD button, speak your message clearly into the built-in microphone (just below the SNOOZE button).
3. When finished, release RECORD/PLAY button .
4. To check your message: press and release the RECORD/PLAY button.
5. To record a new message, repeat steps 1 to 3.

To Turn ON the Display Backlight

1. Press the SNOOZE button. The light will come on for 5 seconds.
2. The light will also come ON when the alarm goes off.

Battery Information

My Voice! Alarm Clock requires three (3) AAA (LR3) batteries (not included).

Adults! To Replace Batteries

1. Use a small Phillips head screwdriver to loosen the screw in the battery compartment door on the back of the toy (Fig. 6). Note: Screw will not detach from battery compartment door.
2. Remove the old batteries.
3. Insert the 3 batteries as shown by battery markings in compartment.
4. Replace the battery door and tighten screw.

Battery Safety:

- Only adults should install and replace batteries.
- Do not recharge non-rechargeable batteries.
- Remove dead or exhausted batteries.
- Insert batteries correctly. Match positive and negative signs.
- Do not place anything across the battery terminals.
- Only use the batteries specified above.
- Do not use rechargeable batteries
- Do not mix alkaline, standard (carbon-zinc), or rechargeable (nickel-cadmium) batteries.
- Do not mix old and new batteries.
- Do not dispose batteries in a fire; they may explode.
- Dispose of batteries safely.

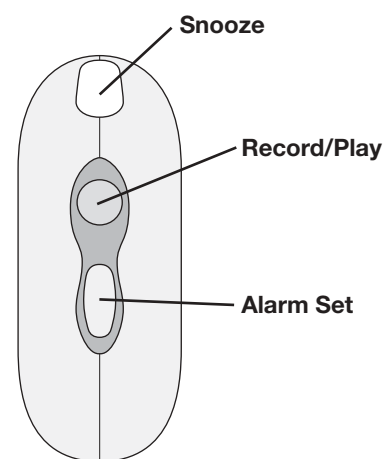

Fig. 5

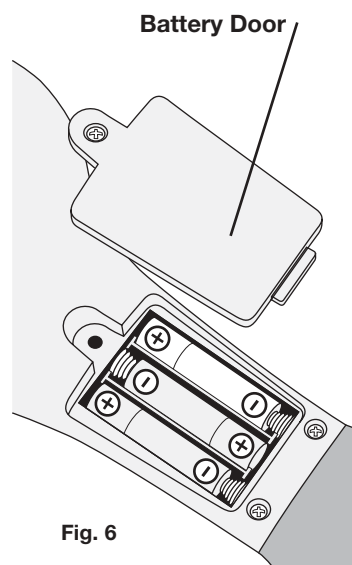

Fig. 6



MY VOICE! ALARM CLOCK 85002-4000-G1 PR 07/04

IF YOU HAVE ANY QUESTIONS, PLEASE CONTACT US AT
1-800-247-6570
WWW.WILDPLANET.COM
©2003 Wild Planet Toys, Inc.
P.O. Box 194087 San Francisco, CA 94119-4087



WARNING:

**CHOKING HAZARD: Small Parts.
Not for Children Under 3 Years.**